

# Stella Care

## SWIVEL BASIN MIXER

### Features

- Can be installed to comply with AS1428.1
- Long handle for easy reach and operation
- Swivel function
- Made from solid brass
- 40 mm cartridge
- PEX split-resistant flexible hoses
- **WELS 5 Star rated, 5L/min**

**Please note:** This product may have a visible Fienza or Watermark logo.

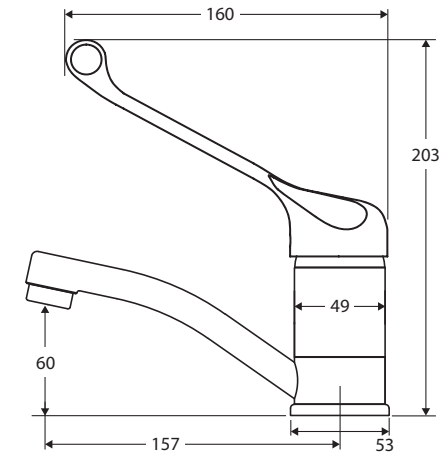

### Available in



Polished Chrome  
**211104D**

### Cleaning & Care

- Regularly clean with mild soapy water using a microfibre cloth.
- In highly polluted or coastal locations, we recommend cleaning 2-3 times per week.
- Do not use harsh detergents, bleach, cream cleaners or citrus based cleaners. These substances are abrasive and will damage the surface.
- Do not use undue pressure and wipe in one direction only.



We aim to ensure that specifications are correct at the time of publication. All measurements are shown in millimetres. Always use measurements of actual product received for final specification as the technical drawing may contain differences. Due to printing limitations, physical colour may vary from the image shown. Fienza reserves the right to make modifications without prior notice.