

Bahama

FREESTANDING SOLID SURFACE BATH, 1500MM

Features

- Captivating asymmetrical design, freestanding style
- Built-in overflow
- Chrome pull-out/pop-up waste included
- Made from smooth and durable solid surface material
- Net weight: 120kg
- Gross weight: 160kg

Installation Warning: Floor preparation may be required for off-centre waste positions. Please discuss with your builder/plumber before tiling and waterproofing your bathroom.

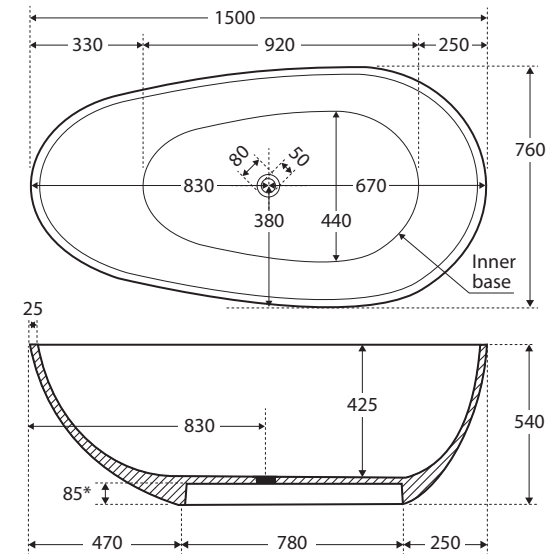

Available in



Matte White
ST03-1500

Cleaning & Care

- Wipe with a clean, soft cloth and mild soapy water or non-abrasive bathroom cleaner. Test in an inconspicuous area before cleaning the whole bath.
- Avoid placing hot objects, such as hair straighteners, on any surface as these will cause discolouration and marking.
- Spills of hair dye, after-shave lotion, nail polish and remover, aerosol spray and other harsh chemicals should be removed immediately to prevent damage and discolouration. Clean immediately with mild soapy water using a clean, soft cloth.
- Please find more information in the Care Guide for this product online at fienza.com.au

We aim to ensure that specifications are correct at the time of publication. All measurements are shown in millimetres. Always use measurements of actual product received for final specification as the technical drawing may contain differences. Due to printing limitations, physical colour may vary from the image shown. Fienza reserves the right to make modifications without prior notice.