

Vienna GL70 Cast Iron Insert Fireplace

Installation and Operating Instructions



IMPORTANT INFORMATION

Most building regulatory Authorities in Australia require any wood heater installation to comply with Installation Standard AS/NZS 2918:2001. Different states and councils may have varying regulations. Check local building regulations before installing the appliance.

The Vienna GL70 has been tested to ensure that it will meet the appropriate safety Standard requirements if the instructions in this manual are followed. As the safety and emissions performance can be affected by altering the appliance, no modifications are allowed without written permission from the manufacturer.

WE RECOMMEND THAT THE INSTALLATION OF THE HEATER BE CARRIED OUT BY A QUALIFIED INSTALLER.

WARNING: THE APPLIANCE AND FLUE SYSTEM SHALL BE INSTALLED IN ACCORDANCE WITH AS/NZS 2918:2001 AND THE APPROPRIATE REQUIREMENTS OF THE RELEVANT BUILDING CODE OR CODES.

WARNING: APPLIANCES INSTALLED IN ACCORDANCE WITH THIS STANDARD SHALL COMPLY WITH THE REQUIREMENTS OF AS/NZS 4012 & AS/NZS 4013 WHERE REQUIRED BY THE REGULATORY AUTHORITY, I.E. THE APPLIANCE SHALL BE IDENTIFIABLE BY A COMPLIANCE PLATE WITH THE MARKING 'TESTED TO AS/NZS 4012 & AS/NZS 4013'.

ANY MODIFICATION OF THE APPLIANCE THAT HAS NOT BEEN APPROVED IN WRITING BY THE TESTING AUTHORITY IS CONSIDERED TO BE IN BREACH OF THE APPROVAL GRANTED FOR COMPLIANCE WITH AS/NZS 4012 & AS/NZS 4013.

CAUTION: MIXING OF APPLIANCE OR FLUE-SYSTEM COMPONENTS FROM DIFFERENT SOURCES OR MODIFYING THE DIMENSIONAL SPECIFICATION OF COMPONENTS MAY RESULT IN HAZARDOUS CONDITIONS. WHERE SUCH ACTION IS CONSIDERED, THE MANUFACTURER SHOULD BE CONSULTED IN THE FIRST INSTANCE.

CAUTION: CRACKED AND BROKEN COMPONENTS, EG. GLASS PANELS OR CERAMIC TILES, MAY RENDER THE INSTALLATION UNSAFE.

INSTALLING THE HEATER

The Vienna GL70 is designed to be installed in a concrete, brick or stone fireplace which is attached to a chimney and has a non-combustible floor protector.

The flue kit must be installed according to the manufacturer's instructions. The 7" flue spigot in the heater must be fitted with a reducer so that it can be installed with a 6" stainless steel flue system

If the heater is to be installed near combustible materials, it must comply with the following installation safety clearances.

Floor Protector

When installed on a combustible floor, the floor protector beneath the heater should consist of standard bricks (225x110x70mm) laid out measuring 930mm wide x 990mm deep x 110mm high. The heater should then be installed on a second row of bricks 110mm high with an air gap beneath (one brick under each rear corner of the heater and a single row along the front). This will result in ventilation gaps beneath the heater measuring 200x110mm on both sides and 440x110mm at the rear of the heater

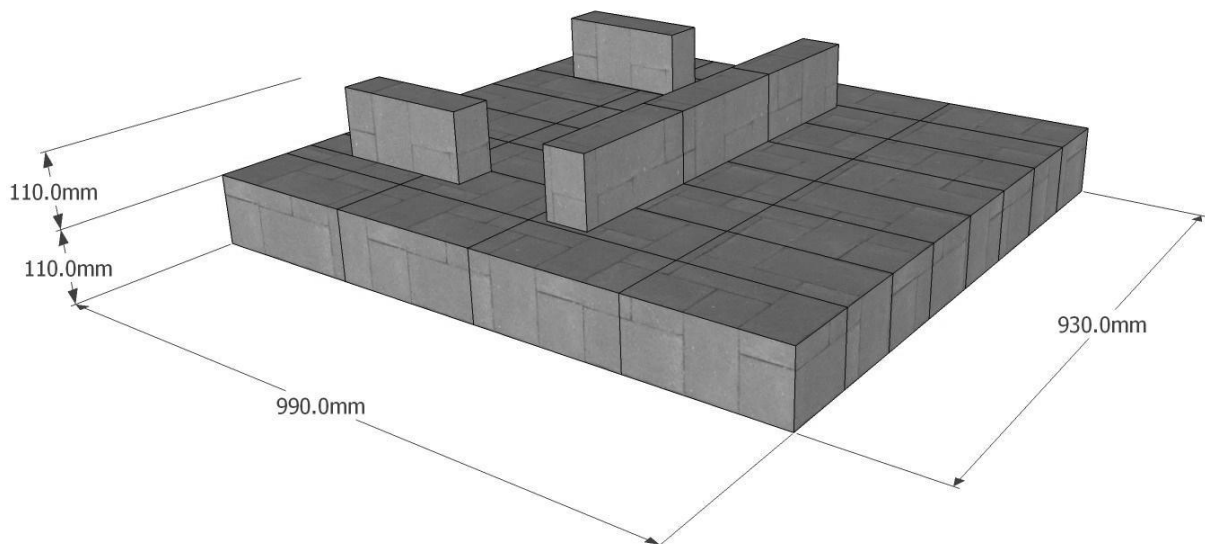

The floor protector must extend a minimum 400mm in front of the heater, and minimum 200mm either side of the door opening (minimum 930mm wide).

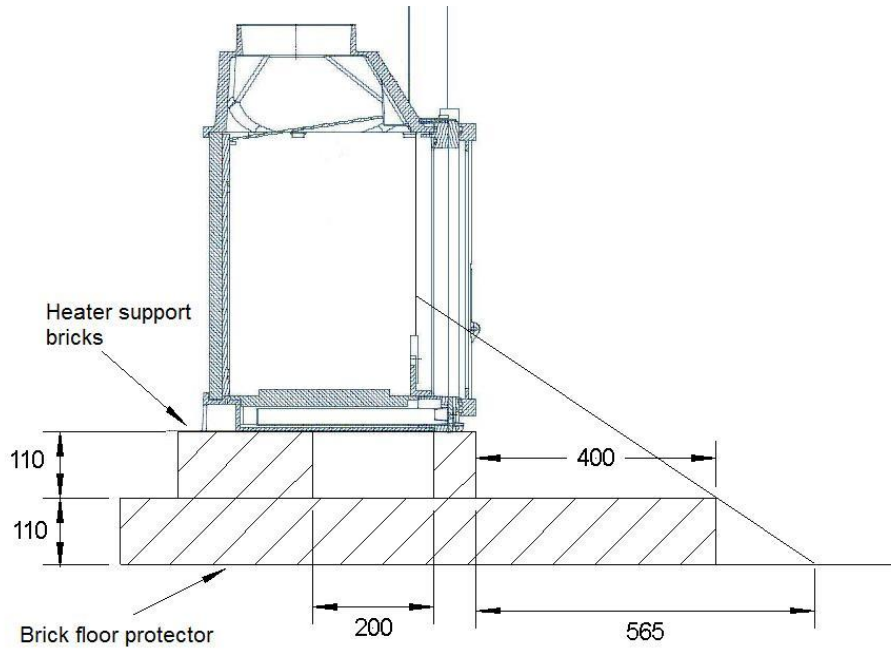

Side and Rear Clearances

a) Standard (parallel) Installation

- Rear wall = 1150mm
- Side wall = 1050mm

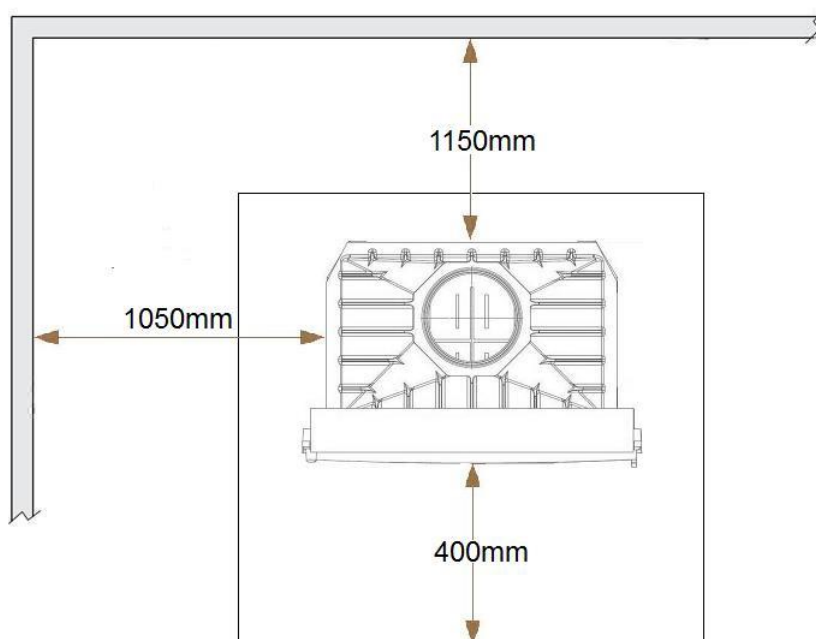

b) Corner Installation

- Side wall = 1000mm

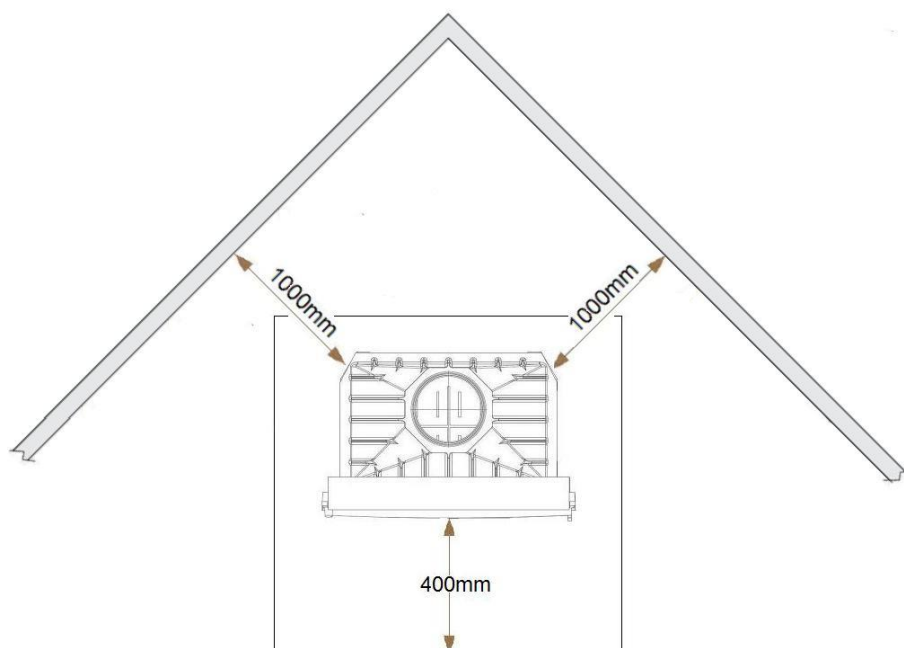

Reducing clearances to combustible walls

If it is necessary to install a heater closer to a combustible surface than the stated requirements in this Installation manual, it must be done in accordance with Australian Standard AS/NZS 2918:2001 Section 3, Tables 3.1 & 3.2.

Shield Construction:- The shield shall be constructed from a heat resistant material. The shield must be fixed to the surface that requires protection and NOT the heater.

The Standard allows three options to reduce stated clearances.

Single layer of continuous material with Minimum Air Gap of 12mm—Clearance Factor = 0.40

Single layer of continuous material with Minimum Air Gap of 25mm—Clearance Factor = 0.30

Two spaced layers of continuous material with Minimum Air Gaps of 12mm + 12mm—
Clearance Factor = 0.20

The shielding must be open at the top and bottom (vented) to allow a continuous air flow. It is this air flow that keeps the surface requiring protection cool. Fixings should not impede this air flow.

The shielding needs to go far enough along and up the wall so that the original side and rear required clearances are not compromised. As the flue is now closer to the wall the shielding should also protect the wall from the flue pipe.

Before use of this appliance please read these instructions fully.

WARNING: ANY MODIFICATION OF THE APPLIANCE THAT HAS NOT BEEN APPROVED IN WRITING BY THE TESTING AUTHORITY IS CONSIDERED AS BREACHING AS/NZS 4013.

WARNING: DO NOT USE FLAMMABLE LIQUIDS OR AEROSOLS TO START OR REKINDLE THE FIRE.

WARNING: DO NOT USE FLAMMABLE LIQUIDS OR AEROSOLS IN THE VICINITY OF THIS APPLIANCE WHEN IT IS OPERATING.

WARNING: DO NOT STORE FUEL WITHIN HEATER INSTALLATION CLEARANCES.

WARNING: WHEN OPERATING THIS APPLIANCE AS AN OPEN FIRE USE A FIRE SCREEN.

WARNING: OPEN AIR CONTROL (AND DAMPER WHEN FITTED) BEFORE OPENING FIRING DOOR.

CAUTION: THIS APPLIANCE SHOULD NOT BE OPERATED WITH A CRACKED GLASS.

CAUTION: THIS APPLIANCE SHOULD BE MAINTAINED AND OPERATED AT ALL TIMES IN ACCORDANCE WITH THESE INSTRUCTIONS.

CAUTION: THE USE OF SOME TYPES OF PRESERVATIVE-TREATED WOOD AS A FUEL CAN BE HAZARDOUS.

The appliance or flue system should not be modified in any way without the written approval of the manufacturer.

Extractor fans or cooker hoods must not be placed in the same room or space as this can cause appliance to emit smoke into the room.

Air Control

The rate at which the wood burns and corresponding heat output is control by a single air control located at the front at the base of the heater. It allows air to enter into the ashpan and through the grate into the firebox.

Opening the door

The can be opened in two ways:

- a) Outward – using the door handle in the centre on the right, release the door and swing open when lighting the fire or loading more wood.
- b) Upward – the door is counter balanced and can be opened upwards. Two tabs on the bottom edge of the door at the front can be used to slide the door up inside the rails.

Refueling the fire

For optimal burning performance generating minimum emissions it is recommended to load the wood in a front to back orientation.

TECHNICAL DRAWINGS

Front View

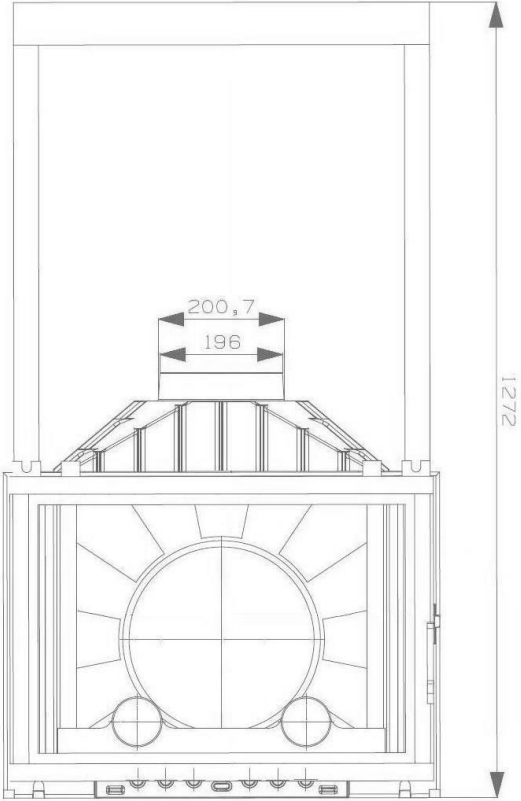

Side View

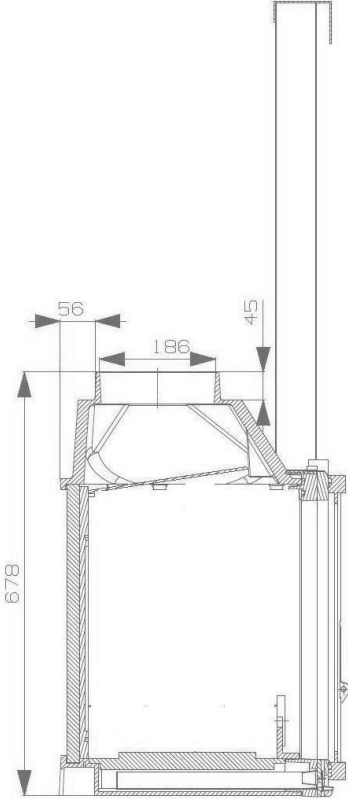

Top View

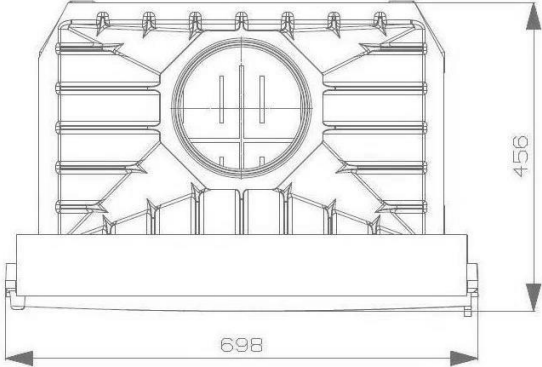

When fitted with high gather the measurement from floor to top of gather 810mm